

TAQ 2 User's Guide

New York Stock Exchange, Inc.

Version 1.1

Microsoft, Microsoft Windows, Windows 95, Windows 98, and Windows NT are registered trademarks of Microsoft Corp. CUSIP is a registered trademark of the American Bankers Association.

Table of Contents

1. The TAQ Database: An Overview	4
2. Installing and Using TAQ2	5
2.1 Hardware and Software Requirements.....	5
2.2 Installing.....	5
2.3 Using TAQ2.....	6
Step 1. Select Data	8
Step 2. Issue	10
Step 3. Data Formats.....	13
Step 4. Filter Data	14
Step 5. Output.....	15
2.4 Technical Support	15
3. File Descriptions	16
3.1 Date File (DATE2.DAT)	16
3.2 CT Binary File (TyyyymmxBIN).....	17
3.3 CT Index File (TyyyymmXIDX).....	24
3.4 CQ Binary File (QyyyymmxBIN).....	25
3.5 CQ Index File (QyyyymmXIDX)	31
3.6 The Master Table (Myyyymm.tab).....	32
3.7 The Dividend File (Dyyyymm.TAB).....	35
Appendix A: Nasdaq Market Makers.....	37
Appendix B: Stock Suffix Table	38
Appendix C: NYSE Trading Systems.....	41
Appendix D: NYSE Industry Codes.....	42

1. The TAQ Database: An Overview

The Trade and Quote (TAQ) database contains intraday transactions data (trades and quotes) for all securities listed on the New York Stock Exchange (NYSE) and American Stock Exchange (AMEX), as well as Nasdaq National Market System (NMS) and SmallCap issues.

TAQ does not include transaction data that is reported *outside* of the Consolidated Tape hours of operation. As of August 2000, those hours are 8:00am to 6:30pm EST. Trading in NYSE-listed securities between 8:00am – 9:30am by other markets are also not in TAQ.

TAQ is available for purchase directly from the New York Stock Exchange. Individual months are available, as well as annual subscriptions. The product is currently delivered on multiple CD-ROM's containing data for one month and is distributed approximately four weeks after the last trading day of each month.

Upgrades to the application – TAQ2.EXE – and other pertinent information can be found on our web site:

www.nyse.com/taq

These data are available at low-cost, designed for sophisticated users participating in research projects. Because of this pricing scheme, only limited support is available for the product. No warranty is made that the data are free of errors and the user assumes all responsibility for the consequences of any errors.

Programs for retrieving trades and quotes for specific days and ticker symbols are available for Windows 9x and NT environments.

Please note that information on the counterparties involved in the trade is NOT included.

2. Installing and Using TAQ2 Data Extraction Program

2.1 Hardware and Software Requirements

The TAQ data extraction program is a 32-bit Windows program that runs on Windows 95, 98, and Windows NT. It will not run on prior versions of Windows

TAQ2.exe Requirements:

CPU:	80486 or better
RAM:	8mb
Operating System:	Windows 9x or NT
Program Disk Space:	1mb for the program
Data Extractions Disk Space:	varies, but 10MB minimum, 500mb recommended

Note: The new version of TAQ2 (January 2000) was written in Object Pascal which has an 'INT64' data type to handle the new, larger 8 byte integers. You may not have the ability to handle 8 byte integers if you are running a version of your C compiler or Unix operating system that is not current. In the latest compilers the 'integer' and 'long integer' data types are synonymous as 4 byte integers. You will need the latest compiler/operating system that has a new data type such as the 'int64' data type mentioned above.

2.2 Installing TAQ2



For the latest information regarding TAQ2, see the file **README.TXT** located in the TAQWIN32 subdirectory on the CD-ROM.

To Install TAQ2 Data Extraction Program

1. Insert the TAQ2 CD-ROM in your CD-ROM drive.
2. Open Windows Explorer (Windows NT Explorer) and copy the TAQWIN32 directory from the TAQ2 CD-ROM and Paste it onto any local or network destination hard drive.
3. Run TAQ2.EXE from the destination hard drive.
4. When you first run the program, it will prompt you for the location of the data files. This can be either the CD-ROM that TAQ2 is delivered on, or you can specify another mass storage location where you copy multiple TAQ2 files for ease of use and better extraction speeds.
5. Exit the program to save your configuration before running any data extractions.

2.3 Using TAQ2

The TAQ2 program allows you to filter and extract just the data you require and output the results in multiple data formats. When you first open the program, a list of all the pre-defined job files is presented to the user. You can run an existing job, run multiple jobs at sequentially, or create a new job. All the jobs are saved in a text file in defined format that can be edited directly using any text editor.

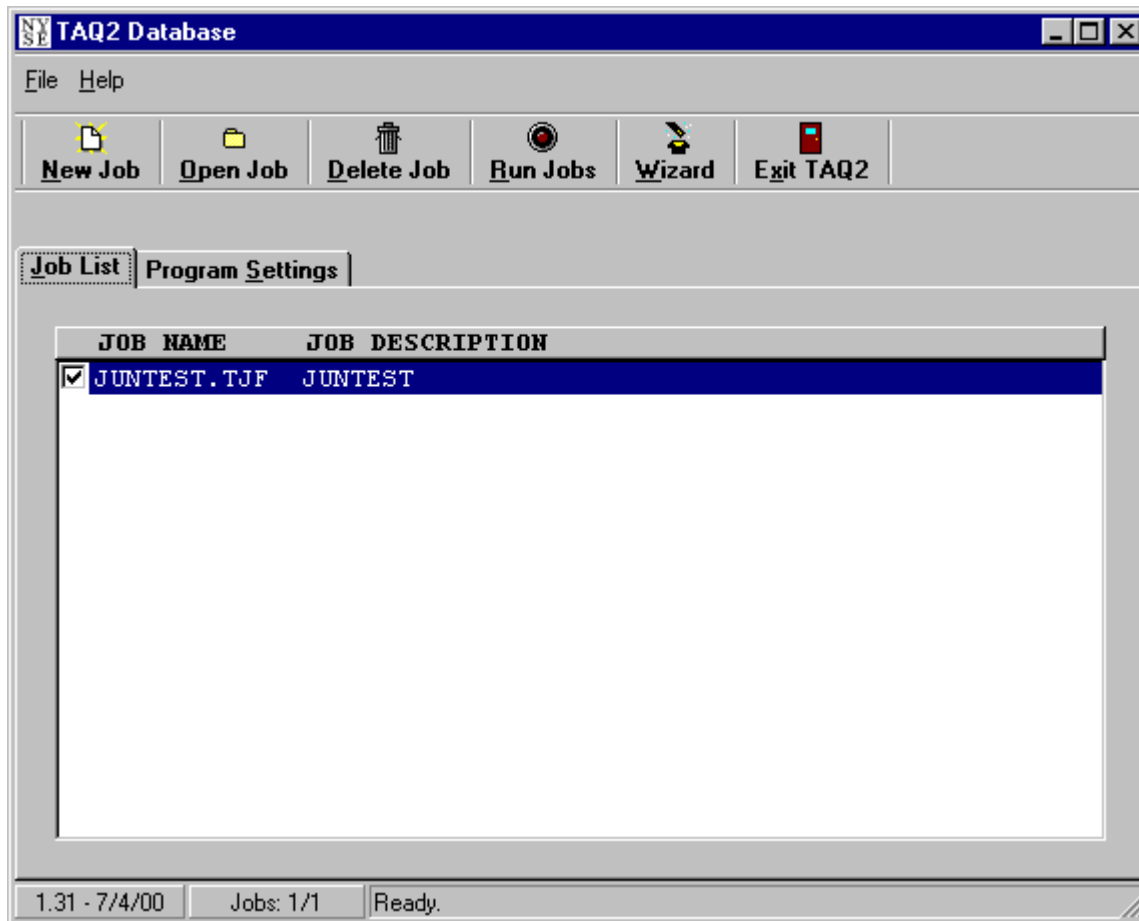

Jobs can also be run from the command line to allow batch processing. For example:

```
C:\taqwin32\Taq c:\taqwin32\jobs\nyse_tech.tjf
```

When running jobs from the command line, the user is not prompted for any menu choices.

A sample TAQ Job File follows on the next page:

Sample Job File:

```
[JOB SETTINGS]
JOB DESCRIPTION=NYSE Technology Stocks
JOB INPUT FILE=F:\TAQ\TAQ2\LISTS\NYSE TECH STOCKS.LST
INPUT OPTIONS=0
OUTPUT OPTIONS=1
TIME FORMAT=1
DATE FORMAT=3
NUMBER FORMAT=1
INPUT LIST TYPE=2
OUTPUT FORMAT=2
INCLUDE QUOTES=1
INCLUDE TRADES=1
INCLUDE V2 FIELDS=0
INCLUDE STATS=1
INCLUDE HEADER=0
INCLUDE MAST=0
INCLUDE DIV=0
OVERWRITE OUTPUT=1
JOB ACTIVE=1
START DATE=9/1/99
END DATE=9/7/99
[ITEM GROUP]
ITEM COUNT=20
ITEM NAME1=ADI
ITEM NAME2=AMD
ITEM NAME3=AOL
:
:
ITEM NAME20=WDC
[QUOTE FIELDS]
QTIM=1
BID=1
OFR=1
QSEQ=1
BIDSIZ=1
OFRSIZ=1
MODE=1
EX=1
MMID=1
BEX=1
AEX=1
CUR=1
[TRADE FIELDS]
TTIM=1
PRICE=1
SIZ=1
TSEQ=1
G127=1
CORR=1
COND=1
EX=1
TISS=1
OC=1
CUR=1
[EXCHANGES]
AMEX=1
BOSTON=1
CINCINNATI=1
MIDWEST=1
NYSE=1
PACIFIC=1
NASD=1
PHILADELPHIA=1
INSTINET=1
CBOE=1
[OUTPUT FILE GROUP]
QUOTES FILE NAME=f:\taq\taq2\output\nyse tech stocks quotes.txt
TRADES FILE NAME=f:\taq\taq2\output\nyse tech stocks trades.txt
TRADES STATS NAME=f:\taq\taq2\output\nyse tech stocks stats.txt
```

Note: Although code is Midwest, it represents Chicago Stock Exchange

Creating a TAQ Job File

Creating a TAQ Job File is simple, merely follow the 5 steps within the program:

Step 1: Select Data

TAQ2 Database - Job Entry Form - [p:\jobs\tradesquotesstats.tif]

File Help

New Job Save Job Default Job Run Job Close Job

Step 1: Select Data Step 2: Select Issue Step 3: Data Formats Step 4: Filter Data Step 5: Output

Job Description:
Trades, Quotes and Stats

Back Next

Process Options:

- Retrieve Trades
- Retrieve Quotes
- Calculate Daily Statistics
- Include Header Information
 - First Record Only
- Include Mast Information
- Include Div Information
- Include Corrections

Time Period:

- Pick Ranges
- CD Contents
- Last Year
- Current Year
- Latest Month
- 1st Quarter
- 2nd Quarter
- 3rd Quarter
- 4th Quarter
- Latest Quarter

Date Range:

Month Of: [v]

Start Date: 4/ 4/00 [v]

End Date: 4/ 4/00 [v]

Time Period:

- Full Day
- Selected Time

Time Range:

Start Time: 5:51:46 PM [v]

End Time: 5:51:46 PM [v]

1.31 - 7/4/00 Symbols: 1 Job Saved Successfully!

- **Job Description:** This is used to describe the job in detail. It is not the file name.
- **Process Options:** You can choose to extract trades, quotes, statistics, or any combination thereof.
 - **Include Header Information:** Creates a line at the top of the output file with the names of the fields. This is convenient if loading the data into a spreadsheet or identifying the fields while viewing the data. First Record Only allows the header only to be shown once for the entire output.
 - **Include MAST Information:** Specifies if you want to include security master file information. This information is shown at the beginning of each security's data within each extraction file.
 - **Include DIV Information:** For NYSE listed stocks only. Specifies whether the dividend information should be included prior to each security's data within each extraction file.
 - **Include Corrections:** Additional records that describe the type of error a trade may have had (see CORR in Section 3.2).
- **Job Options:** An Active job will be included in the "Run Jobs" option when you first start the program. This attribute can be modified at any time.

- **From/To dates:** Choose the date range you wish to extract. If the date range is outside the range of data contained the current TAQ CD-ROM, the program will prompt you to load the correct CD. If you have copied all the data to a mass storage device, the program will automatically traverse each CD in sequential order to extract the data.
- **Time Range:** Choose Selected Time in the Time Period box, then time of day you wish to extract in Time Range.

Step 2: Issue

TAQ2 Database - Job Entry Form - [p:\jobs\tradesquotesstats.tif]

File Help

New Job Save Job Default Job Run Job Close Job

Step 1: Select Data Step 2: Select Issue Step 3: Data Formats Step 4: Filter Data Step 5: Output

Input Type:
 Ticker Symbols
 Cusip Numbers

Input Source:
 Selected Securities
 Attached File
 All Securities

Enter Symbol:
[] [v]

Symbols to Process:
AOL
GE
MSFT

Back Next

Linked Symbol List File:
[] [] []

1.31 - 7/4/00 Symbols: 3 Ready.

- **Input Type:** Choose whether you want to choose securities by Ticker Symbol or by CUSIP Number.
- **Input Source:** Specifies whether you want to choose all the securities, selected securities as specified in the ticker symbol window, or whether you want to link to an ASCII file containing ticker symbols (one ticker symbol per line).
- **Linked File:** If Attached File is chosen, then specify the location and name of the ticker-symbol/CUSIP-number input file.
- **Enter Symbol:** Use this field to enter symbols. Then press the Enter key or the down arrow button located to the right of the field after each symbol to add it to the Symbols to Process list. To find out what each button in this section means, hover your mouse pointer over each button for a balloon description.

Saving the Ticker Symbols or CUSIP Numbers to a List File:

After you have entered tickers into the input box, you can optionally save them to a linked List file by pressing the



The following window will appear:

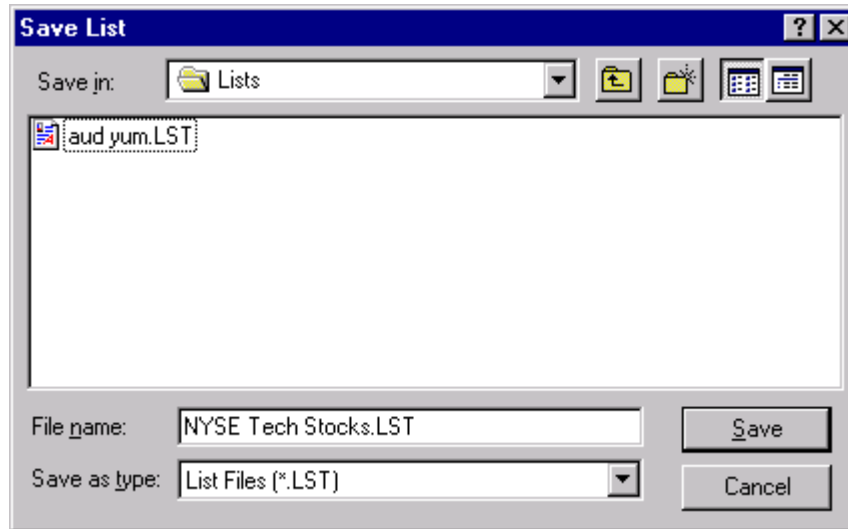

Enter the filename and press Save.

Linking a List File:

Under the “Input Source” items, choose “Attached File”. Then below under “Linked File”, choose the Link List button:



Choose the list file you created by highlighting the name and pressing Open:

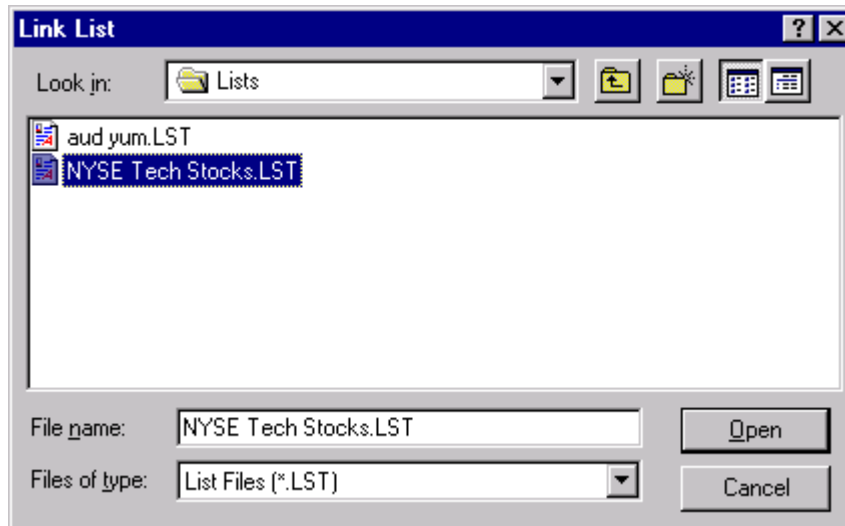

You can edit this list by pressing the “Edit the Input List” button in the “Linked File section (button on the far right):



The following window will appear:

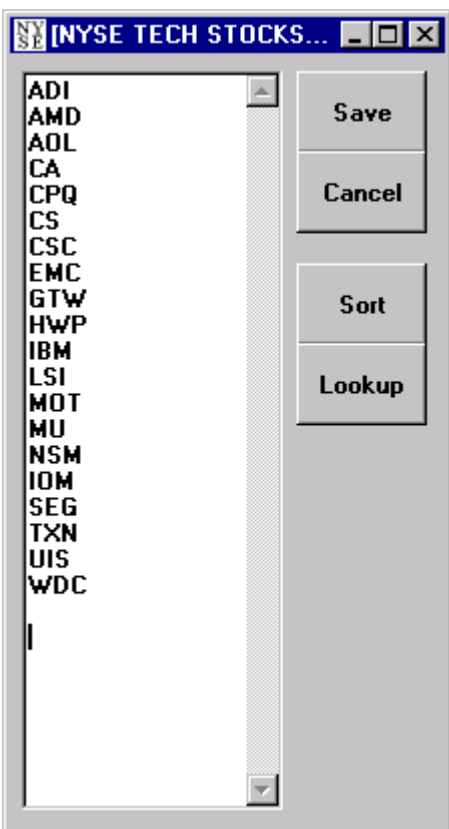

You will see the Ticker Symbols or CUSIP numbers you entered. Press the Lookup button for assistance in locating tickers from Master file.

Step 3: Data Formats

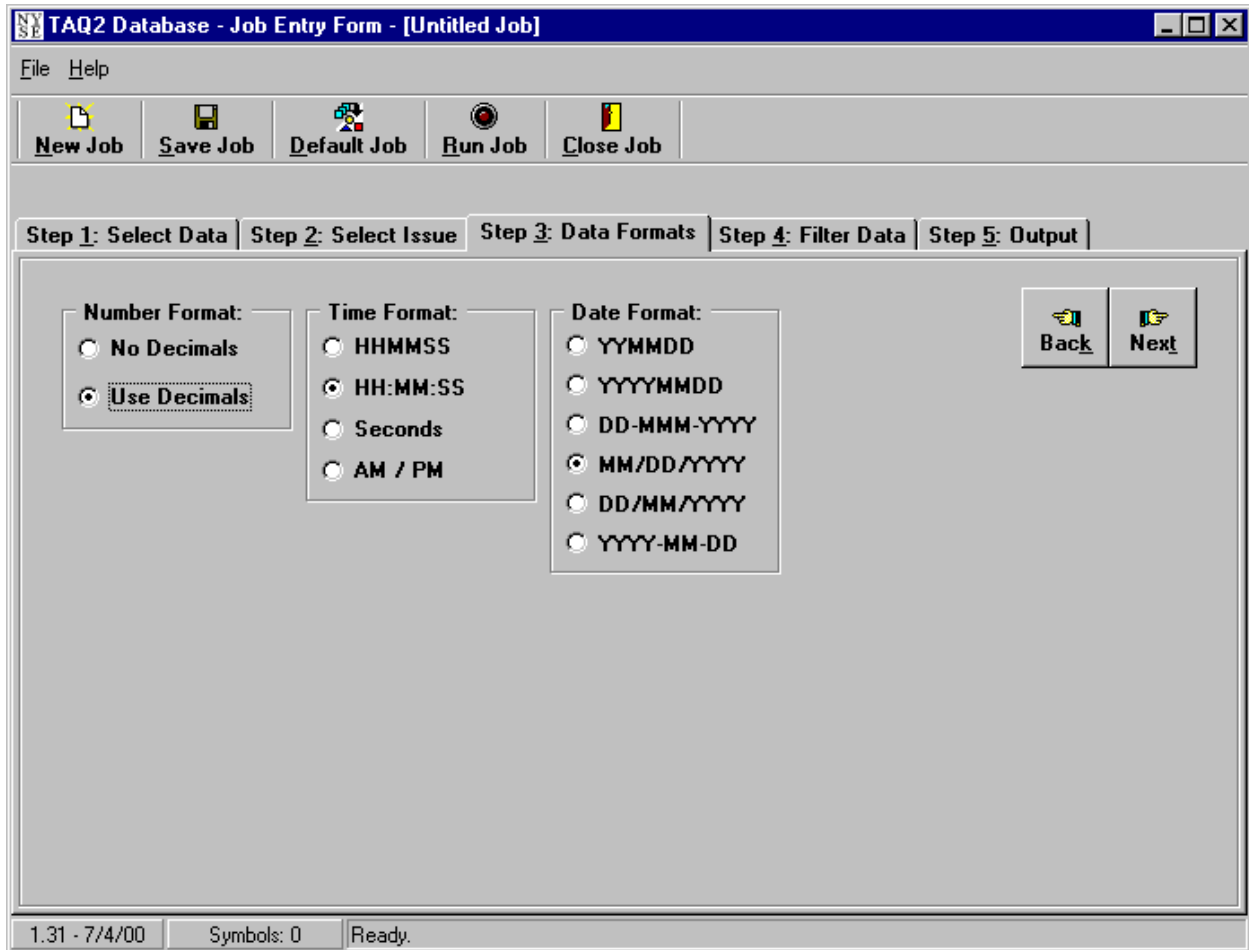

TAQ2 Database - Job Entry Form - [Untitled Job]

File Help

New Job Save Job Default Job Run Job Close Job

Step 1: Select Data Step 2: Select Issue Step 3: Data Formats Step 4: Filter Data Step 5: Output

Number Format:

- No Decimals
- Use Decimals

Time Format:

- HHMMSS
- HH:MM:SS
- Seconds
- AM / PM

Date Format:

- YYMMDD
- YYYYMMDD
- DD-MMM-YYYY
- MM/DD/YYYY
- DD/MM/YYYY
- YYYY-MM-DD

Back Next

1.31 - 7/4/00 Symbols: 0 Ready.

This step allows you to choose the how your data will be formatted. The options are self-explanatory.

Step 4: Filter Data

TAQ2 Database - Job Entry Form - [Untitled Job]

File Help

New Job Save Job Default Job Run Job Close Job

Step 1: Select Data Step 2: Select Issue Step 3: Data Formats Step 4: Filter Data Step 5: Output

Quote Fields:

- EX
- TIME
- BID
- BID SIZE
- OFR
- OFR SIZE
- MODE
- QSEQ
- MMID

Select None

Trade Fields:

- EX
- TIME
- PRICE
- SIZE
- COND
- CORR
- TSEQ
- G127

Select None

Exchanges:

- A-AMEX
- B-BOSTON
- C-CINCINNATI
- M-MIDWEST
- N-NYSE
- P-PACIFIC
- T-NASD
- X-PHILADELPHIA
- O-INSTINET
- W-CBOE

Select None

Back Next

1.31 - 7/4/00 Symbols: 0 Ready.

TAQ allows you to selectively choose the fields that you want to show in the output files. Additionally, you can filter your data extractions by particular stock exchanges:

Note: Instinet (O) now clears under NASD so this code will not be in current CD's. It was only valid during January and February 1993.

Step 5: Output

The output can go to a file or screen and you can view the output by pressing the View Output button. There are 4 of output types described below and ASCII can be brought into many applications. If you need space or are finished with previous queries you can check the Overwrite Existing Files box. To create output files just enter a filename in the space provided. By default, if a directory is not specified, the program will automatically save the files to the Output subdirectory of the main program directory.

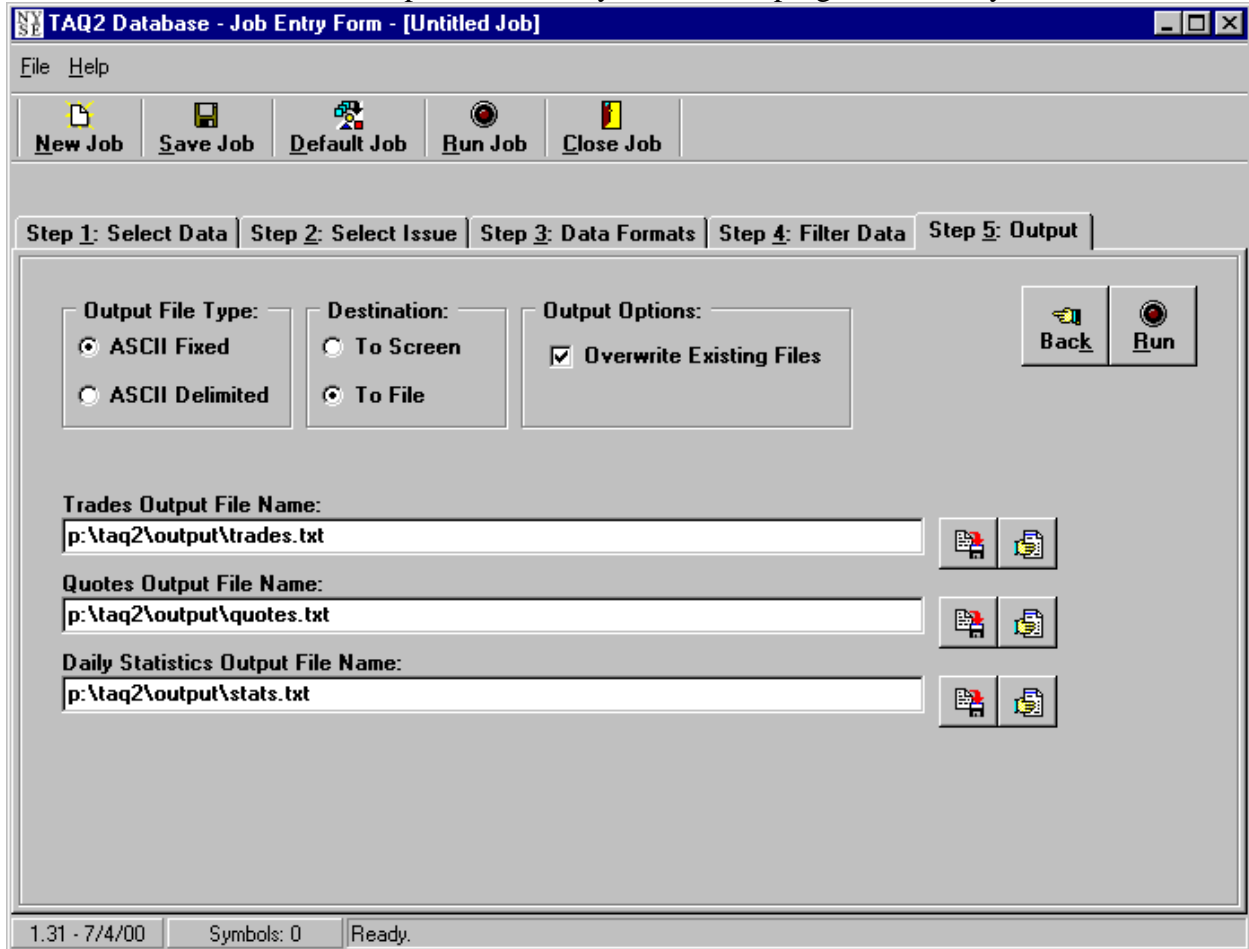

TAQ2 Database - Job Entry Form - [Untitled Job]

File Help

New Job Save Job Default Job Run Job Close Job

Step 1: Select Data Step 2: Select Issue Step 3: Data Formats Step 4: Filter Data Step 5: Output

Output File Type:
 ASCII Fixed
 ASCII Delimited

Destination:
 To Screen
 To File

Output Options:
 Overwrite Existing Files

Back Run

Trades Output File Name:
p:\taq2\output\trades.txt

Quotes Output File Name:
p:\taq2\output\quotes.txt

Daily Statistics Output File Name:
p:\taq2\output\stats.txt

1.31 - 7/4/00 Symbols: 0 Ready.

2.4 Technical Support

Limited support for the TAQ database (only to the one contact person on the contract) is available via Internet by sending e-mail to TAQSUPPORT@NYSE.COM. Also, go to www.nyse.com/taq for other information and updates.

3. File Descriptions

3.1 Date File (DATE2.DAT)

The date file DATE2.DAT is written in character format with a fixed record length of 44 bytes (46 bytes including the carriage return and line feed). It contains trading dates beginning with January 1993 and four fields that indicate the start/end position in each of the binary index files for each trading date. Also, a field indicating which CD-ROM (since there are more than one per month) and a data format of new versions.

Field Name	Layout	Description
TDATE	Character 8 bytes	Transaction date. Format: yyymmdd
CQIDXB	Character 8 bytes	Start position in Qyyymmxx.IDX.
CQIDXE	Character 8 bytes	End position in Qyyymmxx.IDX.
CTIDXB	Character 8 bytes	Start position in Tyyymmxx.IDX.
CTIDXE	Character 8 bytes	End position in Tyyymmxx.IDX.
<i>Space</i>	Character 1 byte	
DISK	Character 2 bytes	Disk where the data resides. If this field is blank, the entire data set is contained on 1 disk for that month. Letters are used to designate the disk. For example: "A" is disk 1, "B" is disk 2, etc.
<i>Space</i>	Character 1 byte	
DATAFMT	Character 1 byte	Data Format. Over the years there have been changes to the data format. Please refer to the user documentation contained on each CD to obtain the correct format for each version. This document contains changes for TAQ2 version 1.0 (DATAFMT = 2). DATAFMT = 0 was for pre-April, 1994 and DATAFMT=1 was the version through December 31, 1999.

3.2 CT Binary File (TyyyymmxBIN)

The Consolidated Trade binary file, TyyyymmxBIN, is written in binary integer format with a fixed record length of 29 bytes (without ending carriage return or line feed). The letter 'x' in the filename is the letter of the CD the file resides on.

Note 1: Beginning in June 1995, the trade time for NYSE and AMEX issues is the Consolidated Trade System (CTS) time stamp. Beginning in March 1997, the trade time for Nasdaq issues is the NTDS time stamp. Previously, the time shown for all trades was the time the message was received by IGS, which is approximately 3 seconds later than the CTS time stamp.

Note 2: Market-On-Close (MOC) Prints¹. When there is an imbalance in MOC orders, the imbalance is executed at the close of trading against the bid or offer on the NYSE, as appropriate, thereby setting the closing price. (An imbalance of buy orders would be executed against the offer. An imbalance of sell orders would be executed against the bid.) The remaining buy and sell MOC orders are then paired off at the closing price set by the imbalance trade. The “pair-off” trade should be reported as “stopped stock”. (See the G127 field.)

Note 3: Prior to August 1993, conditions of A and D were assigned the values of acquisition and distribution, respectively. These actions were governed by NYSE Rule 392, which was rescinded in August 1993. An "Exchange Distribution" or "Exchange Acquisition" occurred when a member or member firm, acting as either agent or principal, asked another member or member firm to buy or sell a block of a security. This action required Exchange approval and was done only when the regular market could not absorb the supply.

¹ For more information, see Hasbrouck, Sofianos, and Sosebee (1993), "New York Stock Exchange Systems and Trading Procedures," Working Paper #93-01, New York Stock Exchange, p.46-47.

Field Name	Layout	Description
TTIM	Binary 4 bytes	Trade time. This number reflects the time at which the trade entered CTS. Format: cumulative number of seconds since midnight.
PRICE	Binary 8 bytes	Actual trade price per share. Truncated to eight implied decimal places.
SIZ	Binary 4 bytes	Number of shares traded.
TSEQ	Binary 4 bytes	Market Data Systems (MDS) sequence number. This field applies only to NYSE trades. It will contain a zero if the trade is not an NYSE trade or if the sequence number is indeterminate.
G127	Binary 2 bytes	<p>Combined "G", Rule 127, and stopped stock trade indicator. This field applies only to NYSE trades.</p> <p>For example, a trade that is Display Book-reported (40) and complies with Rule 127 (100) would appear as 140 in the file.</p> <ul style="list-style-type: none"> 0 = Does not qualify as "G", Rule 127, or stopped stock trade 2 = "G" trade buyer and seller 3 = "G" trade buyer 4 = "G" trade seller 10 = Elect box stroked 20 = Percent box stroked 40 = A Display Book-reported trade. 100 = Rule 127 trade 200 = Stopped stock trade <p style="text-align: right;">(Cont'd on next page)</p>

Field Name	Layout	Description
G127 (cont'd)		<p><i>"G" trade</i> - A member firm trading for its own account must publicly identify that the order is principal. (See NYSE Constitution and Rules, ¶2090, Rule 90.)</p> <p><i>Rule 127</i> – An NYSE trade reported as having been executed as a block position. (See NYSE Constitution, ¶2127, Rule 127.)</p> <p><i>Stopped stock</i> - A guarantee by the specialist that an order will be executed at a specific price. (See NYSE Constitution, ¶2116, Rule 116.)</p>
CORR	Binary 2 bytes	<p>Correction Indicator. Beginning in June 1995, corrections to corrections are permissible. TAQ shows only the original trade and final correction. No interim corrections are shown.</p> <p><u>Good trades:</u></p> <ul style="list-style-type: none"> 0 Regular trade that was not corrected, changed, or signified as cancel or error. 1 Original trade which was later corrected. This record contains the original time and the corrected data for the trade. 2 Symbol correction (out of time sequence). <p><u>Original trade records:</u></p> <ul style="list-style-type: none"> 7 Trade cancelled due to error. 8 Trade cancelled. 9 Trade cancelled due to symbol correction. <p><u>Correction instructions:</u></p> <ul style="list-style-type: none"> 10 Cancel record (associated with 8). 11 Error record (associated with 7). 12 Correction record (associated with 1; contains corrected time and original data).

Field Name	Layout	Description
COND	Character 4 bytes	<p>Sale Condition. These conditions apply to trades on all exchanges except as indicated. More than one code can be displayed in the field (up to four codes).</p> <p>Regular Way (blank or *) - A trade made without any stated conditions.</p> <p>Note: Effective June 7, 1995 the standard settlement cycle was changed from five business days to three business days.</p> <p>Cash-Only Basis (A) - All trading in that issue for that day is on a 'cash only' basis. Every trade for that day will have a condition of A. (See Note 3 at the beginning of this section.)</p> <p>Bunched (B) - A trade representing an aggregate of two or more regular trades (other than the opening or reopening trade) that were executed within the same 60 second period at the same price.</p> <p>Cash Sale (C) - A transaction which calls for the delivery and payment of securities on the same day the trade took place.</p> <p>Next day Settlement Only (D) - All trading in that issue for that day is for 'next day settlement' only. Every trade for that day will have a condition of D. (See Note 3 at the beginning of this section.)</p> <p>NYSE Direct+ (E) - The high-speed electronic connection for immediate automatic execution (Auto-X) of limit orders up to 1,099 shares.</p>
		<p>Bunched sold (G) - A bunched trade not reported within 90 seconds of execution.</p> <p style="text-align: right;">(Cont'd on next page)</p>

Field Name	Layout	Description
COND (cont'd)		<p>Rule 127 trade (J) - (NYSE only) An NYSE trade reported as having been executed as a block position.</p> <p>(See NYSE Constitution and Rules, ¶2127, Rule 127.)</p> <p>Rule 155 trade (K) - (AMEX only) A specialist must give precedence to agency orders in any stock before executing a purchase or sale for the same stock in which he/she has an interest. (See Amex Constitution and Rules, ¶9295, Rule 155.)</p> <p>Sold last (L) - A transaction that occurs in sequence but is reported to the tape at a later time; there are no intervening trades between the time the transaction occurs and when it is reported.</p> <p>Next day (N) - Calls for delivery of securities on the first business day following the day of the contract.</p> <p>Opened Last (O) - An opening trade that occurs in sequence but is reported to the tape at a later time.</p> <p>Prior Reference Price (P) - (NASD only) An executed trade that occurred in a marketplace where members execute certain transactions that actually relate to an obligation to trade at an earlier point in the trading day or that refer to prior referenced price.</p> <p style="text-align: right;">(Cont'd on next page)</p>

Field Name	Layout	Description
COND (cont'd)		<p>Seller (R) - "Seller's Option". Delivery date is specified by the seller and must be between two and sixty calendar days following the day of the contract (but not on the third business day after the trade date, which is considered <i>regular way</i>).</p> <p>(See NYSE Constitution and Rules, ¶2064, Rule 64.)</p> <p>Note: Beginning in June 1995, values over 60 are permissible. Any value over 99 has been changed to 99.</p> <p>Split Trade (S) - (NASD only) An execution that takes place in two markets. The market-maker in the first market agrees to execute a portion of an order at a price realized in another market, to which the balance of the order is forwarded for execution.</p> <p>Pre- and Post-Market Close Trades (T) - (NASD only) A trade that occurred within the current trading day, but is executed outside of the current market hours and within the market reporting hours. These trades include:</p> <ul style="list-style-type: none"> • European market between 9:06 and 9:13 EST; • U.S. market between 8:00 and 9:30 EST; • U.S. market between 16:00 and 17:16 EST. <p>Average Price Trades (W) - A trade where the price reported is an average of the prices for transactions during all or any portion of the trading day. Applies to Nasdaq NMS and SmallCap issues and to listed (CTS) issues only during European Market session.</p> <p style="text-align: right;">(Cont'd on next page)</p>

Field Name	Layout	Description																				
COND (cont'd)		<p><i>Opened after trading halt if reporter checked the open box (X) – Information unavailable at this time.</i></p> <p><i>Sold Sale (Z) - A transaction that is reported to the tape at a time later than it occurred and when other trades occurred between the time of the transaction its report time.</i></p> <p><i>Crossing Session (8, 9) - one record per symbol for executed volume entered as one-sided orders (9) and one record per symbol for executed volume entered as two-sided orders (i.e., matched) at the closing price (8). There are no individual records for executed one-sided or two-sided orders.</i></p> <p>(For details on Crossing Session, see NYSE Market Surveillance Information Memo 91-19, June 5, 1991.)</p>																				
EX	Character 1 byte	<p>Exchange on which the trade occurred.</p> <table data-bbox="760 915 1235 1066"> <tr> <td>A</td> <td>AMEX</td> <td>P</td> <td>Pacific</td> </tr> <tr> <td>B</td> <td>Boston</td> <td>T</td> <td>NASD</td> </tr> <tr> <td>C</td> <td>Cincinnati</td> <td>X</td> <td>Philadelphia</td> </tr> <tr> <td>M</td> <td>Chicago</td> <td>W</td> <td>CBOE</td> </tr> <tr> <td>N</td> <td>NYSE</td> <td></td> <td></td> </tr> </table>	A	AMEX	P	Pacific	B	Boston	T	NASD	C	Cincinnati	X	Philadelphia	M	Chicago	W	CBOE	N	NYSE		
A	AMEX	P	Pacific																			
B	Boston	T	NASD																			
C	Cincinnati	X	Philadelphia																			
M	Chicago	W	CBOE																			
N	NYSE																					

3.3 CT Index File (Tyyyymm.x.IDX)

The Consolidated Trade index file, Tyyyymm.x.IDX, is written in binary integer format with a fixed record length of 22 bytes (without ending carriage return or line feed). The letter 'x' in the filename is the letter of the CD the file resides on.

The TDATE field is 4 binary bytes in the format: yyyymmdd.

Field Name	Layout	Description
SYMBOL	Character 10 bytes	Stock symbol. (See Appendix C.)
TDATE	Binary 4 bytes	Transaction date. Format: yyyymmdd
BEGREC	Binary 4 bytes	Start position.
ENDREC	Binary 4 bytes	End position.

3.4 CQ Binary File (QyyyymmxBIN)

The Consolidated Quote binary file, QyyyymmxBIN, is written in binary integer format with a fixed record length of 39 bytes (without ending carriage return or line feed). The letter 'x' in the filename is the letter of the CD the file resides on.

Note 1: For January 4, 1993 through April 6, 1993, the bid and offer sizes for Nasdaq NMS issues are invalid. They have been zero-filled.

Note 2: Nasdaq NMS quotes after 4:00 p.m. may contain zero bid or offer sizes. These are valid end-of-day quotes. NASD quotes with mode 12 and zeroes in the BIDSIZ, OFRSIZ, BID, and OFR fields represent quotes withdrawn by the market maker (MMID) submitting the zero quotes.

Note 3: Beginning in August 1993, the data files include a market maker identification field with every NASD quote in exchange-listed issues. The addition of this field makes it possible to accurately calculate the BBO among Nasdaq market makers and all market centers.

Note 4: Beginning in March 1996, the quote time for NYSE and AMEX issues is the Consolidated Quote System (CQS) time stamp. Beginning in November 1996, the quote time for Nasdaq issues is the NQDS time stamp. Previously, the time shown for all quotes was the time the message was received by IGS, which is approximately a 3 seconds later than the CQS time stamp.

Field Name	Layout	Description
QTIM	Binary 4 bytes	Quote time. This number reflects the time at which the quote entered CQS. Format: cumulative number of seconds since midnight.
BID	Binary 8 bytes	Bid price. Truncated to eight implied decimal places.

Field Name	Layout	Description
OFR	Binary 8 bytes	Offer price. Truncated to eight implied decimal places.
QSEQ	Binary 4 bytes	Market Data Systems (MDS) sequence number. This field applies only to NYSE quotes. It contains a zero if the quote is not an NYSE quote or if the sequence number was indeterminate.
BIDSIZ	Binary 4 bytes	Bid size in number of round lots (100 share units).
OFRSIZ	Binary 4 bytes	Offer size in number of round lots (100 share units).
MODE	Binary 2 bytes	<p>Quote condition. These conditions apply to quotes on all exchanges except as indicated.</p> <p>Zero (0) - invalid field for that issue (e.g., Nasdaq NMS issue).</p> <p>Depth on offer side (1) - Indicated more size behind the quote being disseminated for the offer. This depth may be at the ask price of the quote or at a price immediately outside the disseminated ask quote.</p> <p>Depth on bid side (2) - Similar to Mode 1 in indicating depth, but only for bid quotation.</p> <p style="text-align: right;">(Cont'd on next page)</p>

Field Name	Layout	Description
MODE (cont'd)		<p><i>Closing quote (3)</i> – Indicates the last quote from a participant for that security during the trading day. There may be two closing quotes per symbol at the same price for market-on-close (MOC) transactions.²</p> <p><i>News dissemination (4)</i> - A regulatory halt used when relevant news influencing the stock is disseminated. Trading is suspended until the resultant impact has been assessed.</p> <p><i>Fast trading (5)</i> - Used during extremely active periods of short duration. While in this mode, quotes are entered on a "best efforts" basis.</p> <p><i>Depth on bid and offer (6)</i> - Indicated more size behind the reported quote for both bid and offer. The depth may be either at or immediately outside the quote.</p> <p><i>Order imbalance (7)</i> – A non-regulatory halt used when there is a severe buy or sell order imbalance. To prevent a disorderly market, trading is temporarily suspended.</p> <p><i>Closed market maker (NASD) (8)</i> - This condition is disseminated by each market maker to signify either the last quote of the day or the premature close of a market maker for the day. In the latter case, the market maker can re-open by transmitting a quote accompanied by Mode 12.</p>

²For more information, see Hasbrouck, Sofianos, and Sosebee (1993), "New York Stock Exchange Systems and Trading Procedures," Working Paper #93-01, New York Stock Exchange, p.46-47.

Field Name	Layout	Description
MODE (cont'd)		<p>Non-firm quote (9) - A regulatory halt used when the level of trading activity in a security is such that the Exchange cannot collect, process, and disseminate quotes that accurately reflect market conditions. The specialist, with Floor Official approval, may switch to "non-firm mode" for 30 minutes.³</p> <p>(See NYSE Constitution and Rules, ¶2060, Rule 60.)</p> <p>Opening quote (10) – The first quote disseminated from a given market center for each security.</p> <p>News pending (11) – Indicates a regulatory trading halt or delayed opening due to an expected news announcement which may influence trading in the stock. A trading halt or opening delay may be reversed once the news has been disseminated.</p> <p>Regular (NASD open) (12) - Indicates normal trading environment. May be used by NASD market makers in place of Mode 10 to indicate the first quote of the day or if a market maker re-opens a security during the day (see Mode 8).</p> <p>Trading halt due to related security (13) - A non-regulatory halt used when events relating to one security will affect the price and performance of another security (e.g., a tender offer).</p> <p style="text-align: right;">(Cont'd on next page)</p>

³For more information, see Hasbrouck, Sofianos, and Sosebee (1993), "New York Stock Exchange Systems and Trading Procedures," Working Paper #93-01, New York Stock Exchange.

Field Name	Layout	Description
MODE (cont'd)		<p><i>Trading halt in view of common (14)</i> - A non-regulatory trading halt used when matters that affect the common stock of a company may affect the performance of other classes of securities for the same company.</p> <p><i>Order influx (15)</i> - A non-regulatory halt used when there is a severe influx of buy and sell orders. To prevent a disorderly market, trading is temporarily suspended.</p> <p><i>No open/no resume (16)</i> - Indicates a trading halt or an opening delay is to be in effect for the rest of the trading day. Generally, a trading halt condition indicating the reason for the halt or delay is indicated prior to the input of Mode 16.</p> <p><i>Opening (Re-opening) Price (17, 18)</i> - Indicates the probable trading range (bid and offer sizes, no prices) of a security that is not opening delayed or halted. This quote condition can be used prior to (17) or after (18) the opening of a security.</p> <p><i>Related Security News dissemination (19)</i> - A regulatory halt used when news relating to one security will affect trading in an associated security. For example, news pertaining to the common issues of a company may affect the preferred issues.</p> <p><i>Related Security News pending (20)</i> - Same as above but refers to expected news.</p> <p>(Cont'd on next page)</p>

Field Name	Layout	Description																				
MODE (cont'd)		<p>Additional Information (27) - A regulatory halt or delayed opening used if more disclosure of information for the security is requested by the exchange. If inadequate information is disclosed during a trading halt or delayed opening due to news dissemination (mode 4) or news pending (mode 11), the reason could subsequently be reported as mode 27.</p> <p>Additional Information due to related security (28) - A regulatory halt or delayed opening used if more disclosure of information for the security is requested for a related security.</p> <p>Resume (29) - Used with zero-filled bid and offer sized to indicate that quoting is no longer suspended for a security that was halted or delayed.</p> <p>Related Security News pending (20) - Same as above but refers to an expected news announcement.</p>																				
EX	Character 1 byte	<p>Exchange on which the quote occurred.</p> <table border="0"> <tr> <td>A</td> <td>AMEX</td> <td>P</td> <td>Pacific</td> </tr> <tr> <td>B</td> <td>Boston</td> <td>T</td> <td>NASD</td> </tr> <tr> <td>C</td> <td>Cincinnati</td> <td>X</td> <td>Philadelphia</td> </tr> <tr> <td>M</td> <td>Chicago</td> <td>W</td> <td>CBOE</td> </tr> <tr> <td>N</td> <td>NYSE</td> <td></td> <td></td> </tr> </table>	A	AMEX	P	Pacific	B	Boston	T	NASD	C	Cincinnati	X	Philadelphia	M	Chicago	W	CBOE	N	NYSE		
A	AMEX	P	Pacific																			
B	Boston	T	NASD																			
C	Cincinnati	X	Philadelphia																			
M	Chicago	W	CBOE																			
N	NYSE																					
MMID	Character 4 bytes	<p>Identifies the NASDAQ market maker for each NASD quote. See Appendix B for a list of valid market makers.</p> <p>Note: This field was added in August 1993. Beginning in March 1997, the values AA, AI, IA, and II were replaced with blanks. Previously, these values identified aggregate CAES and non-CAES quotes.</p>																				

3.5 CQ Index File (Qyyymmxx.IDX)

The Consolidated Quote index file, Qyyymmxx.IDX, is written in binary integer format with a fixed record length of 22 bytes (without ending carriage return or line feed). The letter 'x' in the filename is the letter of the CD the file resides on.

The QDATE field is 4 binary bytes in the format: yyyymmdd.

Field Name	Layout	Description
SYMBOL	Character 10 bytes	Stock symbol. (See Appendix C.)
QDATE	Binary 4 bytes	Quote date. Format: yyyymmdd
BEGREC	Binary 4 bytes	Start position.
ENDREC	Binary 4 bytes	End position.

3.6 The Master Table (Myyyymm.tab)

The master table contains reference information about the stocks in the trade and quote files. Some fields apply only to NYSE and/or AMEX issues, and are blank or zero-filled when not applicable to the issue.

For those issues that clear through the National Securities Clearing Corp. (NSCC), there is at least one record. If an issue does not clear through the NSCC, a record will not appear in the master file.

Any time a change occurs in any field pertaining to an issue, there is a new record with a new effective date. Historical records are not carried forward. There is one exception to this rule: if a company changes its name or symbol while retaining its CUSIP, the file will contain two separate unrelated records with the same CUSIP number.

The master file, Myyyymm.tab, is written in character format with a fixed record length of 91 bytes (93 bytes including carriage return and line feed).

Note 1: For January 1993 data, there are five symbols that traded but do not appear in the master file: ARN (American Re Corp), BTZWI (Berlitz Int Inc), SPY (Spider Tr Unit), TIDED (Tide West Oil Co), and VEIX (VAALCO Energy Inc). Master information pertaining to these symbols is available via the NYSE Internet account, and was included with the February 1993 master file.

Note 2: Only listed companies that have been quoted or traded appear in the Master Table.

Field Name	Layout	Description
SYMBOL	Character 10 bytes	Stock symbol. (See Appendix C.)
NAME	Character 30 bytes	Company name.

Field Name	Layout	Description																		
CUSIP	Character 12 bytes	<p>CUSIP number, which uniquely identifies a security. The Committee on Uniform Security Identification Procedure (CUSIP) assigns the first nine digits/characters.</p> <p style="padding-left: 40px;">Digits/characters 1-6 identify the issuer Digits/characters 7-9 identify the issue</p> <p>The last three digits are applied by the NSCC to distinguish between NYSE, AMEX, and NASD issues.</p> <table style="margin-left: auto; margin-right: auto;"> <thead> <tr> <th style="text-align: left;"><u>Issue Type</u></th> <th style="text-align: left;"><u>Extension</u></th> </tr> </thead> <tbody> <tr> <td>NYSE</td> <td>000</td> </tr> <tr> <td>NYSE when issued</td> <td>100</td> </tr> <tr> <td>AMEX</td> <td>001</td> </tr> <tr> <td>AMEX when issued</td> <td>101</td> </tr> <tr> <td>NASD</td> <td>002</td> </tr> <tr> <td>NASD when issued</td> <td>102</td> </tr> </tbody> </table>	<u>Issue Type</u>	<u>Extension</u>	NYSE	000	NYSE when issued	100	AMEX	001	AMEX when issued	101	NASD	002	NASD when issued	102				
<u>Issue Type</u>	<u>Extension</u>																			
NYSE	000																			
NYSE when issued	100																			
AMEX	001																			
AMEX when issued	101																			
NASD	002																			
NASD when issued	102																			
Etr	Character 10 bytes	<p>There is one column for each exchange indicating whether it trades equities in this symbol. Each column contains either a 1 (trades equities) or 0 (no equities). The <i>x</i> suffix refers to the following exchange codes:</p> <table style="margin-left: auto; margin-right: auto;"> <tbody> <tr> <td>N</td> <td>NYSE</td> </tr> <tr> <td>A</td> <td>Amex</td> </tr> <tr> <td>B</td> <td>Boston</td> </tr> <tr> <td colspan="2">2 blank columns</td> </tr> <tr> <td>P</td> <td>Pacific</td> </tr> <tr> <td>X</td> <td>Philadelphia</td> </tr> <tr> <td>T</td> <td>NASD</td> </tr> <tr> <td>O</td> <td>OTC</td> </tr> <tr> <td>W</td> <td>CBOE</td> </tr> </tbody> </table> <p>Note: T indicates that the NASD trades the stock as a non-primary market; O indicates that the NASD trades the stock as a primary market. Therefore, when ETO=1, NASD is the primary market center even though ETT=0.</p>	N	NYSE	A	Amex	B	Boston	2 blank columns		P	Pacific	X	Philadelphia	T	NASD	O	OTC	W	CBOE
N	NYSE																			
A	Amex																			
B	Boston																			
2 blank columns																				
P	Pacific																			
X	Philadelphia																			
T	NASD																			
O	OTC																			
W	CBOE																			

Field Name	Layout	Description
ITS	Character 1 byte	Intermarket Trading System (ITS) eligibility indicator. 1 = ITS-eligible stock. 0 = Not an ITS-eligible stock. Note: NYSE-listed stocks that trade in sixteenths cannot trade through ITS. AMEX-listed stocks that trade in sixteenths are supported by ITS only if the trading price is less than \$5.
ICODE	Character 4 byte	NYSE industry code. (See Appendix E.)
SHARESOUT	Character 10 bytes	Issued and outstanding shares in thousands. This number includes treasury shares.
UOT	Character 4 bytes	Number of shares in a round lot.
DENOM	Character 1 byte	Trading denomination (i.e., tick size) of the stock. B = decimal 3 = 1/8 4 = 1/16 5 = 1/32 6 = 1/64 7 = 1/128 8 = 1/256
TYPE	Character 1 byte	Common stock indicator. 0 = common 1 = preferred 2 = warrant 3 = right 4 = other 5 = derivative
DATEF	Character 8 bytes	Effective date for that record in the format yyymmdd.

3.7 The Dividend File (Dyyyymm.TAB)

The dividend file, Dyyyymm.TAB, contains one record for each symbol that either paid a dividend or redistributed stock during the month. In rare cases, a symbol may have two records for one month. The file is written in character format with a fixed record length of 53 bytes (55 including carriage return and line feed).

Warning: At his point in time, dividend and stock split data included in TAQ are known to be inaccurate for some securities. We are attempting to correct this problem and will keep all users informed of any changes in the reliability of these data. Currently, we recommend using other data sources to verify the data included in TAQ.

Field Name	Layout	Description														
SYMBOL	Character 10 bytes	Stock symbol. (See Appendix C.)														
CUSIP	Character 12 bytes	<p>CUSIP number, which uniquely identifies a security. The Committee on Uniform Security Identification Procedure (CUSIP) assigns the first nine digits.</p> <p>Digits/characters 1-6 identify the issuer Digits/characters 7-9 identify the issue.</p> <p>The last three digits are applied by the NSCC to distinguish between NYSE, AMEX, and NASD issues.</p> <table> <thead> <tr> <th><u>Issue Type</u></th> <th><u>Extension</u></th> </tr> </thead> <tbody> <tr> <td>NYSE</td> <td>000</td> </tr> <tr> <td>NYSE when issued</td> <td>100</td> </tr> <tr> <td>AMEX</td> <td>001</td> </tr> <tr> <td>AMEX when issued</td> <td>101</td> </tr> <tr> <td>NASD</td> <td>002</td> </tr> <tr> <td>NASD when issued</td> <td>102</td> </tr> </tbody> </table>	<u>Issue Type</u>	<u>Extension</u>	NYSE	000	NYSE when issued	100	AMEX	001	AMEX when issued	101	NASD	002	NASD when issued	102
<u>Issue Type</u>	<u>Extension</u>															
NYSE	000															
NYSE when issued	100															
AMEX	001															
AMEX when issued	101															
NASD	002															
NASD when issued	102															
Blank	1 byte															

Field Name	Layout	Description
DIV	Character 10 bytes	Amount of cash dividend if stock is ex-dividend on this date. Five implied decimal places.
Blank	1 byte	
SPLIT/ADJ	Character 10 bytes	Amount of the adjustment made to the price of the symbol due to a stock split, stock distribution, or stock dividend. Rounded up to nearest eighth. Five implied decimal places.
Blank	1 byte	
DATEF	Character 8 bytes	Date of stock split or dividend.

Appendix A: Nasdaq Market Makers

Nasdaq Market Makers mnemonics can be found using the National Securities Clearing Corporation (NSCC) Directory or at the NSCC website www.nsccl.com under Member Directory where an electronic version can be downloaded. Below is a sample list.

MMID	Company Name
(blank)	Aggregate quote, valid only for Nasdaq issues.
AA	Bid and offer are CAES aggregates*
AI	Bid is CAES aggregate; offer is non-CAES or exchange aggregate*
CAES	NASD Market Services, Inc.
DEAN	Dean Witter Reynolds Inc.
FAHN	Fahnestock & Co., Inc.
IA	Bid is non-CAES or exchange aggregate; offer is CAES aggregate*
II	Bid and offer are non-CAES or exchange aggregates*
LEHM	Lehman Bros.
MADF	Madoff (Bernard L.)
NASD	End of day quote for that issue
RHCO	Robinson-Humphrey Company Inc.
SHAW	Shaw (D.E.) Securities
TRIM	Trimark Securities, Inc.

* This value only valid prior to March 1997.

Appendix B: Stock Suffix Table

NYSE and AMEX Issues

All securities on the NYSE and AMEX are identified by a three-character symbol. The following table lists the valid four- to seven-character suffix identifiers.

<u>Description</u>	<u>Suffix Symbol</u>
Class A	A
Class A Called	ACL
Class A Convertible	ACV
Class A When Issued	AWI
Class B	B
Class B Called	BCL
Class B Convertible	BCV
Class B When Issued	BWI
Called	CL
Certificate	CT
Convertible	CV
Convertible Called	CVCL
Ex-Dividend	XD
Ex-Rights	XRT
Without Warrants	XW
Part Called	PTCL
Preferred	PR
Preferred A through Preferred Z	PRA through PRZ
Preferred Called	PRCL
Preferred When Issued	PRWI
Rock Island Certificate UP	CTUP
Rights	RT
Rights When Issued	PRWI
Special	SP
Stamped	SD
Warrants	WS
Warrants Class A	WSA
Warrants Class B	WSB
Warrants When Issued	WSWI
With Warrants	WW
When Distributed	WD
When Issued	WI

Nasdaq Issues

Stock symbols. A unique four- or five-letter symbol assigned to a Nasdaq security. If a fifth letter appears, it identifies the issue as other than a single issue of common stock or capital stock. A list of fifth-letter identifiers and a description of what each represent follows:

<u>Description</u>	<u>Suffix</u>
Class A	A
Class B	B
Issuer qualification exception - the issuer has been granted a continuance in NASDAQ under an exception to the qualification standards for a limited period.	C
New	D
Delinquent in required filings with the SEC.	E
Foreign	F
First convertible bond	G
Second convertible bond, same company	H
Third convertible bond, same company	I
Voting	J
Nonvoting	K
Miscellaneous situations, such as depositary receipts, stubs, additional warrants, and units	L
Fourth preferred, same company	M
Third preferred, same company	N
Second preferred, same company	O
First preferred, same company	P
Bankruptcy - The issuer is involved in bankruptcy proceedings.	Q
Rights	R
Shares of beneficial interest	S
With warrants or with rights	T
Units	U
When-issued and when-distributed	V
Warrants	W
ADR (American Depositary Receipt)	Y
Miscellaneous situations, such as depositary receipts, stubs, additional warrants, and units	Z

Source: Nasdaq website: <http://www.nasdaq.com/reference/glossary.stm>

Suffix Definitions

Called - an issue being redeemed by its issuing corporation under definite conditions before maturity.

Certificate - refers to a negotiable certificate representing deposit of stock with a pending change in its condition.

Convertible - a preferred share which its owner may convert into common stock or another security, usually in the same company, in accordance with the terms of issue.

Preferred - class of stock with priority over common stock in regard to earnings and/or liquidations.

Rights - represent the privilege to subscribe (in proportion to the number of shares owned) to new or additional securities, usually at or below the current market price. Rights ordinarily have market values of their own and are actively traded. In most cases they must be exercised within a relatively short period of time.

Stamped - indicates rights and privileges different from securities of the same issue, class, or series not stamped.

Warrant - indicates a certificate giving its holder the right to purchase securities at a stipulated price, either within a specified time limit or perpetually.

When Distributed - signifies a short form of “when, as, and if distributed” (see When Issued).

When Issued - means a short form of “when, as, and if issued”; indicates a transaction in a security authorized for issuance, but not yet issued. All “when issued” transactions are on an “if” basis, to be settled if and when the actual security is issued.

With Warrants - a security with a warrant attached that entitles the holder to purchase another security at stipulated price(s), either within a specified time or in perpetuity. Warrants may be immediately detachable from their underlying securities or detachable after specified periods.

Without Warrants - a security from which the warrant(s) has been removed.

Appendix C: NYSE Trading Systems

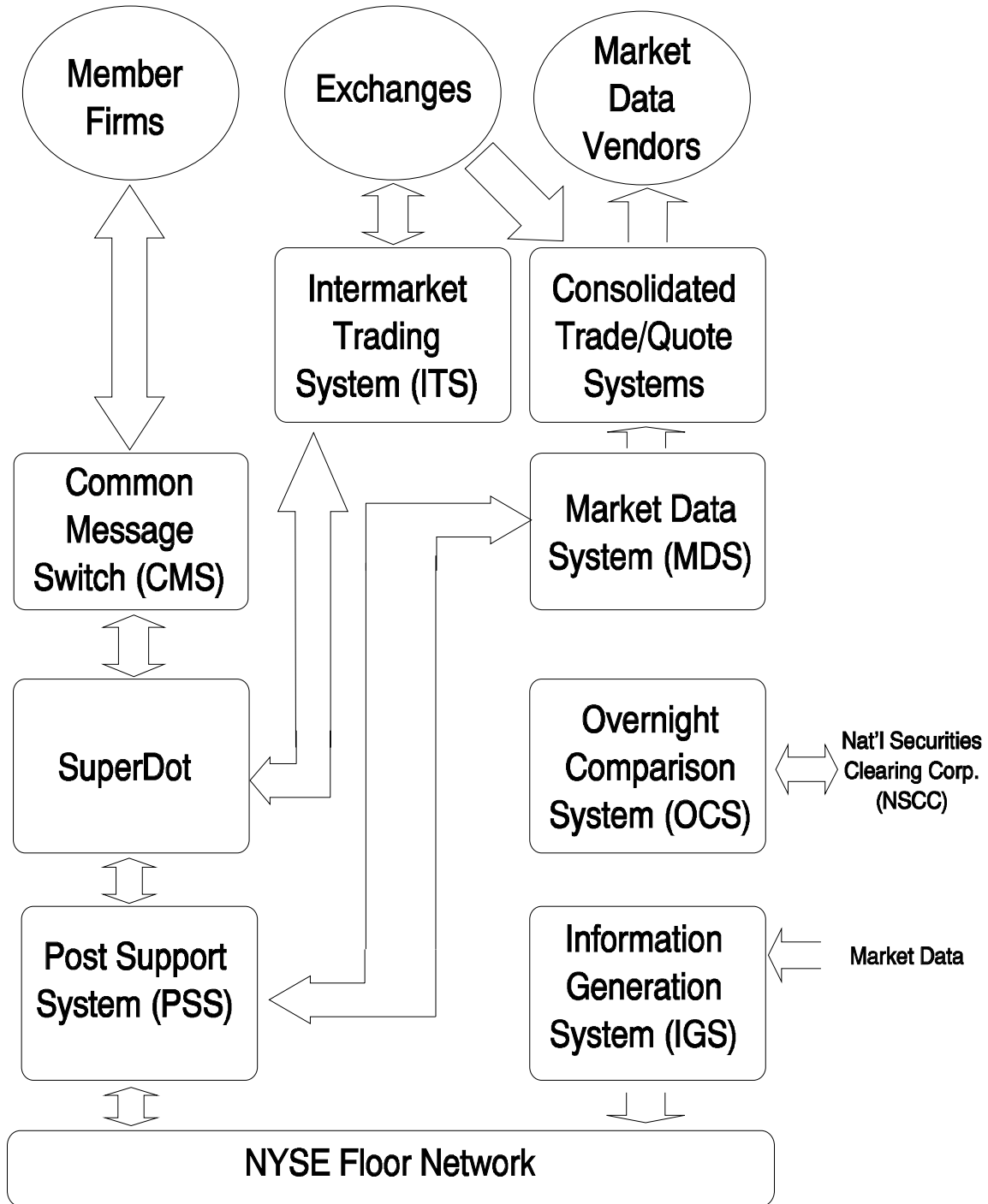

Source: NYSE Equity Systems & Business Development

Appendix D: NYSE Industry Codes

<u>INDUSTRY GROUP</u>	<u>CODE</u>
INDUSTRIALS	100
Aerospace	102
Aircraft	102A
Parts and Equipment	102B
Business Supplies and Services	104
Machines and Equipment (Excl. Computers)	104A
Supplies	104B
Services	104C
Chemicals	106
Diversified Chemicals	106A
Specialized	106B
Computers, Data Processing	108
Computer Systems	108A
Data Processing, Software	108B
Peripheral Devices and Supplies	108C
Construction	110
Residential	110A
Industrial	110B
Cement	110C
Lumber, Wood	110D
Other Building Materials and Products	110E
Electrical Equipment	112
Electronics	114
Semi Conductors and Other Components	114A
Telecommunications Equipment	114B
Test, Control Instruments and Systems	114C
Other Systems and Equipment	114D
Environmental Control	116
Foods, Beverages	118
Beverages	118A
Branded Food Products	118B
Processing and Production	118C
Wholesalers	118D
Health and Beauty Products	120
Personal Health Products	120A
Toiletries, Cosmetics, Perfumes	120B

<u>INDUSTRY GROUP</u>	<u>CODE</u>
Health Care Services	122
Equipment and Supplies	122A
Health Care Facilities	122B
Household Goods	124
Appliances	124A
Furnishings and Fixtures	124B
Housekeeping Products	124C
House-wares	124D
Industrial Machinery and Equipment	126
Heavy Machinery	126A
Machine Tools	126B
Measuring and Control Devices	126C
Transmissions and Engines	126D
Other Industrial Equipment	126E
Lodging, Restaurants	128
Hotels, Motels	128A
Restaurants	128B
Mining, Refining, Fabricating	130
Aluminum	130A
Coal	130B
Gold, Silver	130C
Steel, Iron	130D
Other Non-Ferrous Metals	130E
Motor Vehicles	132
Auto and Truck	132A
Parts and Equipment	132B
Oil and Gas	134
Crude Production	134A
Contract Drilling, Exploration	134B
Integrated Domestic Refiners	134C
Integrated International Refiners	134D
Non-Integrated Refiners	134E
Services and Equipment	134F
Packaging	136
Glass	136A
Metal	136B
Paper	136C
Other	136D
Paper Production	138
Pharmaceuticals	140

<u>INDUSTRY GROUP</u>	<u>CODE</u>
Publishing	142
Newspaper Chains	142A
Magazines	142B
Books	142C
Recreation Services and Products	144
Broadcasting	144A
Gaming Operations and Services	144B
Leisure Time Products	144C
Motion Pictures, Entertainment Services	144D
Outdoor Recreational Vehicles and Equipment	144E
Retail Trade	146
Department Store Chains	146A
Discount Variety Chains	146B
Drug Store Chains	146C
Supermarkets, Food Stores	146D
Hardware, Furniture Stores	146E
Specialty Apparel Shops	146F
Other Retail Operations	146G
Textiles, Apparel	148
Textile and Mill Products	148A
Clothing Companies	148B
Shoes	148C
Tires, Rubber	150
Tobacco	152
Wholesalers, Distributors	154
Consumer Products (Non-Food)	154A
Industrial Products	154B
Multi-Industry	170
Other	180
Manufacturing	180A
Services	180B
TRANSPORTATION	200
Air	202
Passenger Airlines	202A
Freight Airlines	220B
Rail	204
Trucking	206
Other Transportation Services	208

<u>INDUSTRY GROUP</u>	<u>CODE</u>
UTILITIES	300
Electric Services	302
Gas Services	304
Distribution and Integrated Natural Gas Cos.	304A
Natural Gas Transmission Companies	304B
Other Gas Services	304C
Telecommunications	306
Water Supply Companies	308
Multi-Service Companies	310
FINANCE, REAL ESTATE	400
Banks	402
Multinational	402A
Regional	402B
Savings and Loan Associations	402C
Brokerage Services	404
Closed-End Investment Companies	406
Bond Funds	406A
Stock Funds	406B
Specialty Funds	406C
Finance Companies	408
Insurance	410
Brokers, Agents	410A
Carriers	410B
Trusts	412
Real Estate Investment Trusts (REITS)	412A
Oil Royalty Trust	412B
Other Trusts	412C
Real Estate	414
Diversified Financial Services	416